

**London  
Underground**

**A new Tunnel Cleaning Train for  
London Underground**

# Content

- Explore the need for tunnel cleaning
- Provide an overview of the Tunnel Cleaning Train Replacement Project
- Differences between the new machine and the old one
- Learning points (thus far...!)



# Why is tunnel cleanliness important?

- Tunnel dust and dirt affects the performance of assets and provides a poor environment for passengers and our staff.
- Airborne dust levels in the LU network has been a subject of debate, media attention and medical articles
- The dust is primarily iron-based (from the wheel rail interface) and is contributory factor in electrical asset failures



# Why is tunnel cleanliness important?

- Combustible constituents of the dust combines with oil/grease (wheel rail lubrication) and can cause smoke & fire incidents
- LU expends considerable effort cleaning trains and stations



# LU Experience



# LU Experience

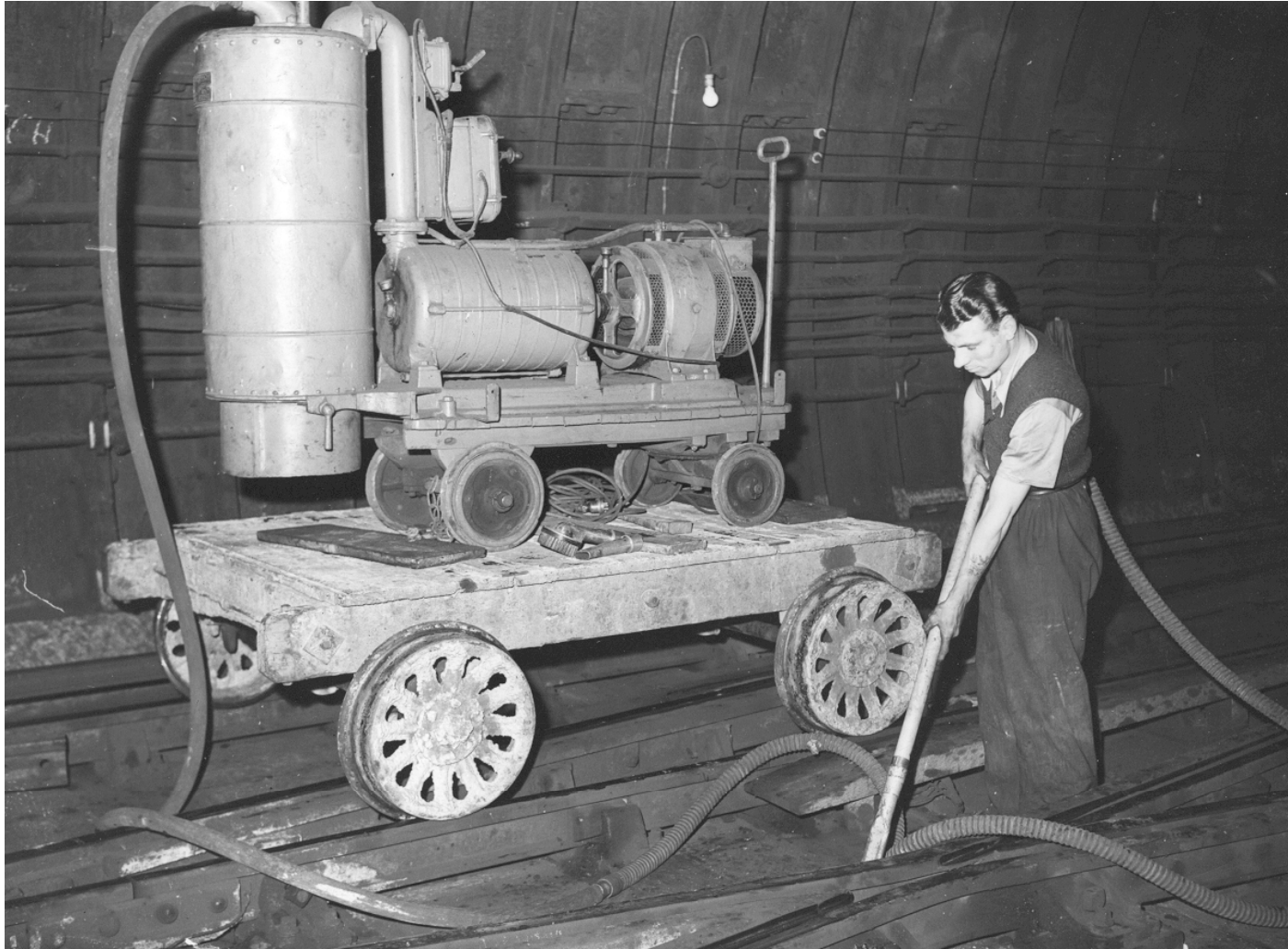

# LU Experience

- In 1976 LUL brought into service a 'tunnel cleaning train'
- Based on 1938 tube stock and used forced air to disturb dust and dirt followed by a vacuum to remove it.

Removed up to 1,000kg of waste per kilometre in heavily contaminated areas, but typically averaged 600kg/km across the network



# LU Experience

- Required multiple passes to clean a single section of tunnel.
- The train was successful at cleaning tunnels but went out of operation due to unreliability and high maintenance and operating costs
- Known to cause dust clouds when it succeeded in disturbing dust but failed to capture it





# Development of new TCT

- Rolling stock standards largely developed for passenger stock, not engineering trains... so early specifications called for a passenger train with a 'Henry' rather than an industrial vacuum attached to a wagon
- Thorough development of requirements was undertaken (technical, operational, HF, safety, etc)... standards were 'brutally hacked', only necessary clauses were included and the applicability of those clauses were defined carefully
- Preferred option was for a specialist supplier to provide a Tunnel Cleaning Unit (TCU) and LU provide a pair of Motive Power Units (MPUs) to haul it around
- LU retains systems integration responsibility which was deemed high risk and therefore costly.



# TCT Architecture

- The supplier of the TCU required to provide the following:
  - Design and construct a TCU (their core competency)
  - Assist LU with the definition of interfaces (power, control, braking, coupling, etc)
  - Test the TCU at a location external to the LU network
  - Test the TCU on the LU network
- LU required provide the following:
  - Creation of the MPUs (2 off) (our core competency)
  - Manage the interface between TCU and MPUs
  - Retain overall system integration responsibility
  - Test the integrated TCT on the LU network

**TCT = MPU + TCU + MPU**  
**= Clean Tunnels**



# What are we getting?

MPU + TCU + MPU

MPU

+

TCU

+

MPU

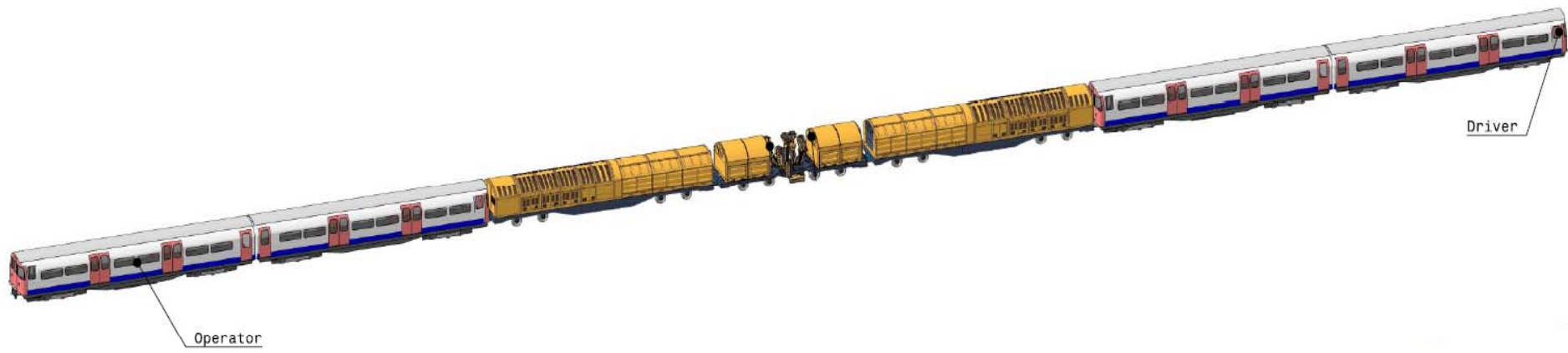

# What are we getting?

MPU + **TCU** + MPU

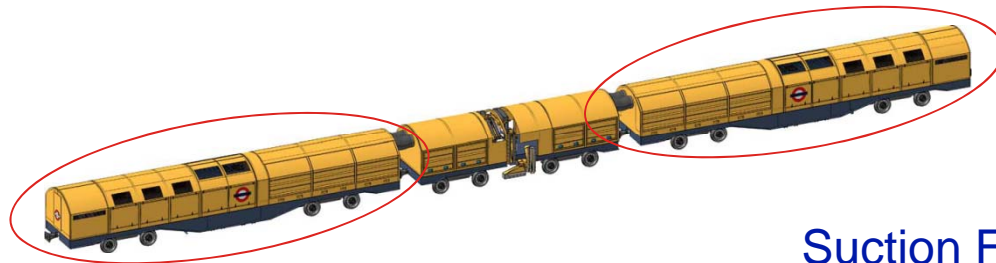

Control System

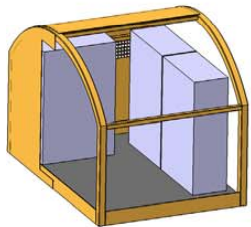

Engine Compartment

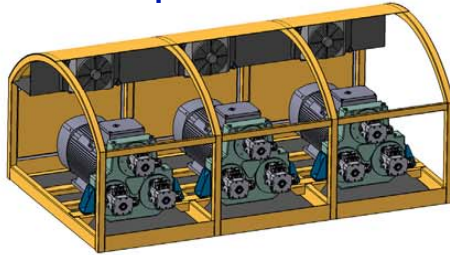

Suction Fan Compartment

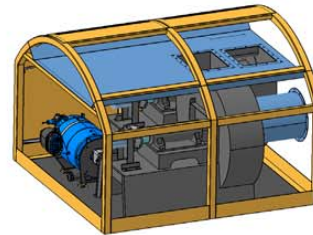

Fine Dust Filter Compartment

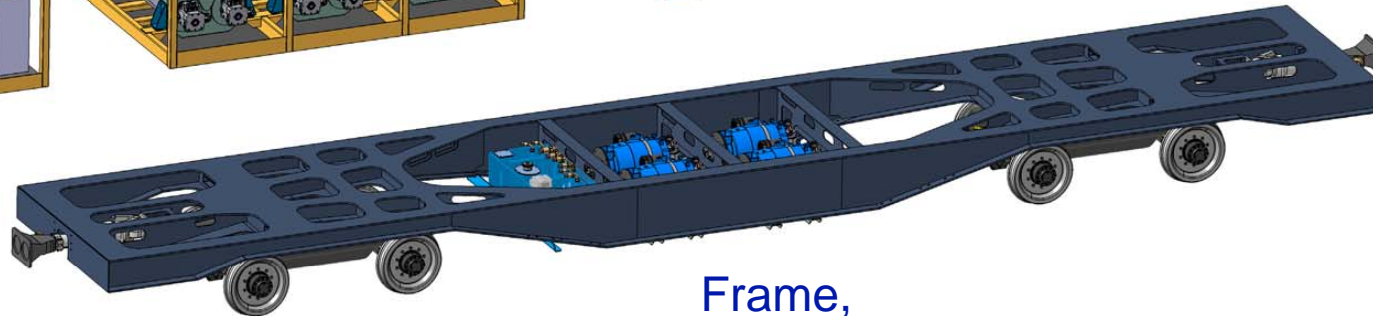
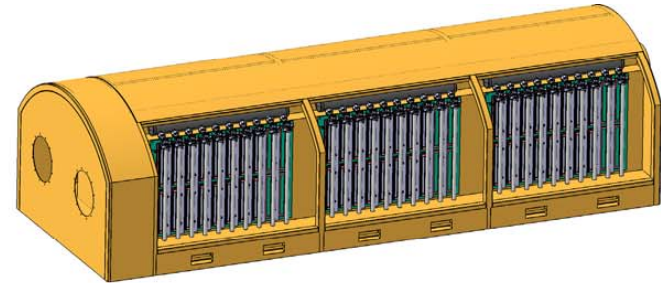

Frame,  
Compressors,  
Bogies, Hydraulics



# What are we getting?

MPU + **TCU** + MPU



Litter & Coarse  
Material Filters

Compressed air  
and vacuum  
Nozzles

Litter & Coarse  
Material Filters



# What are we getting?

MPU + TCU + MPU

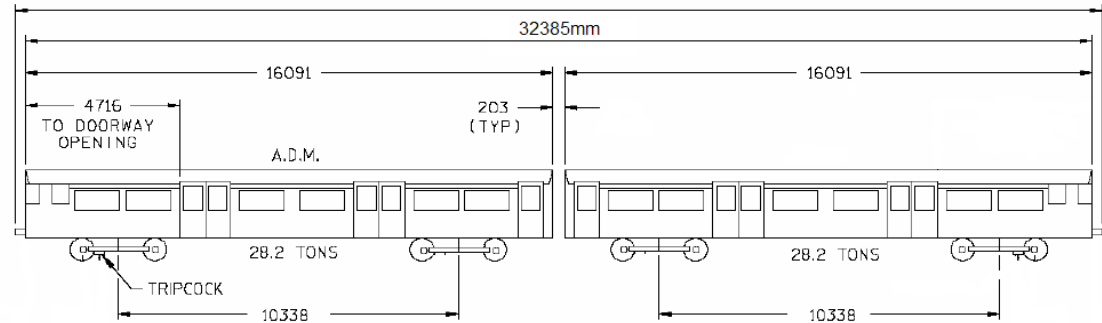

- MPUs will be created through conversion of 4 x Victoria Line motor cars
  - Each MPU consists of two motor cars coupled together
- MPUs will be require significant refurbishment work including:
  - Cab refurbishment and ventilation
  - Full re-wire, component overhaul and removal of door engines
  - Structural enhancements, dust and water sealing and external re-paint
  - Incorporation of TCU cleaning management console... But still less costly than creating new vehicles



# What is different to the old train

- New train uses “Air Curtain” technology.
  - produces very controlled jets of air, rather than a large body of slow moving air.
  - Creates two opposing vacuum streams to capture all dust

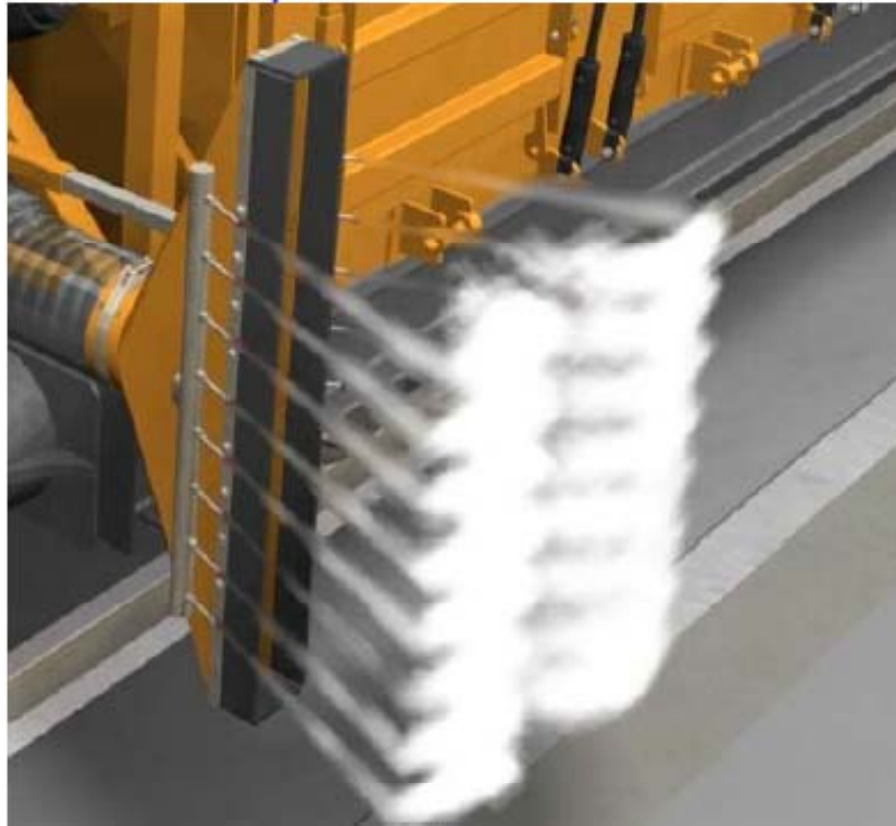

# What is different to the old train

- Layout prevents formation of a dust plume, which was a known issue with the old train.

New Train:

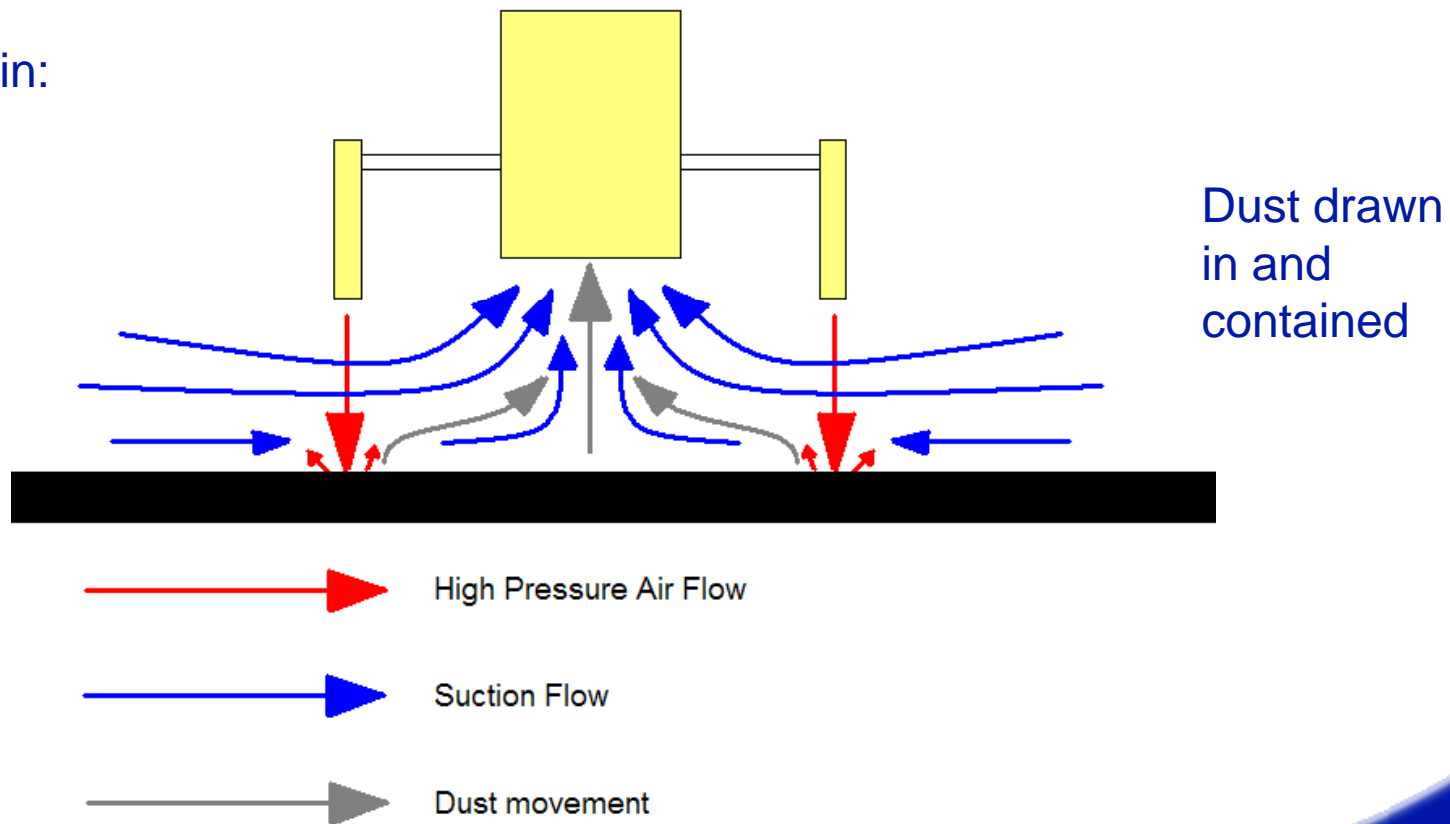



# What is different to the old train

- Layout prevents formation of a dust plume, which was a known issue with the old train.

Old Train:

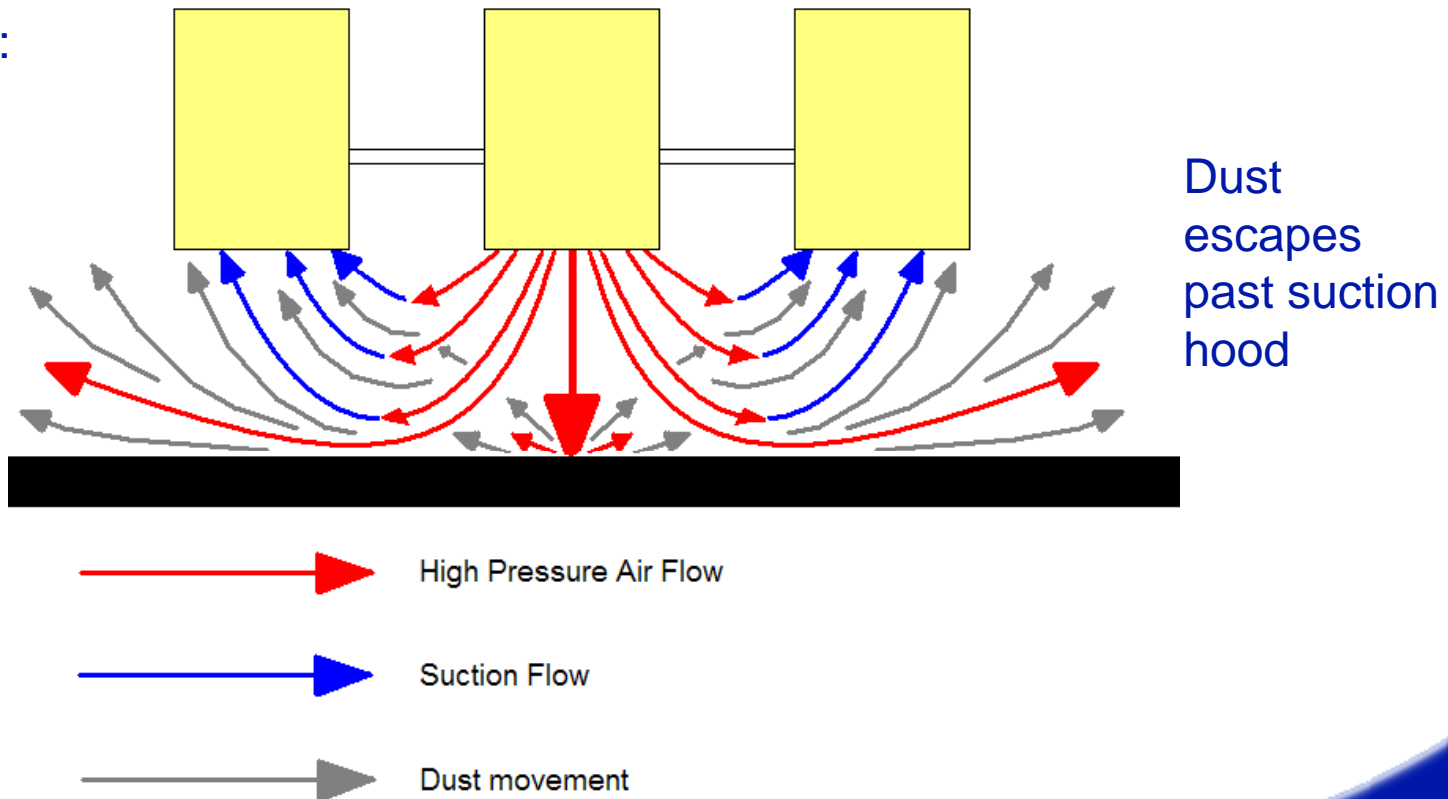

# What is different to the old train

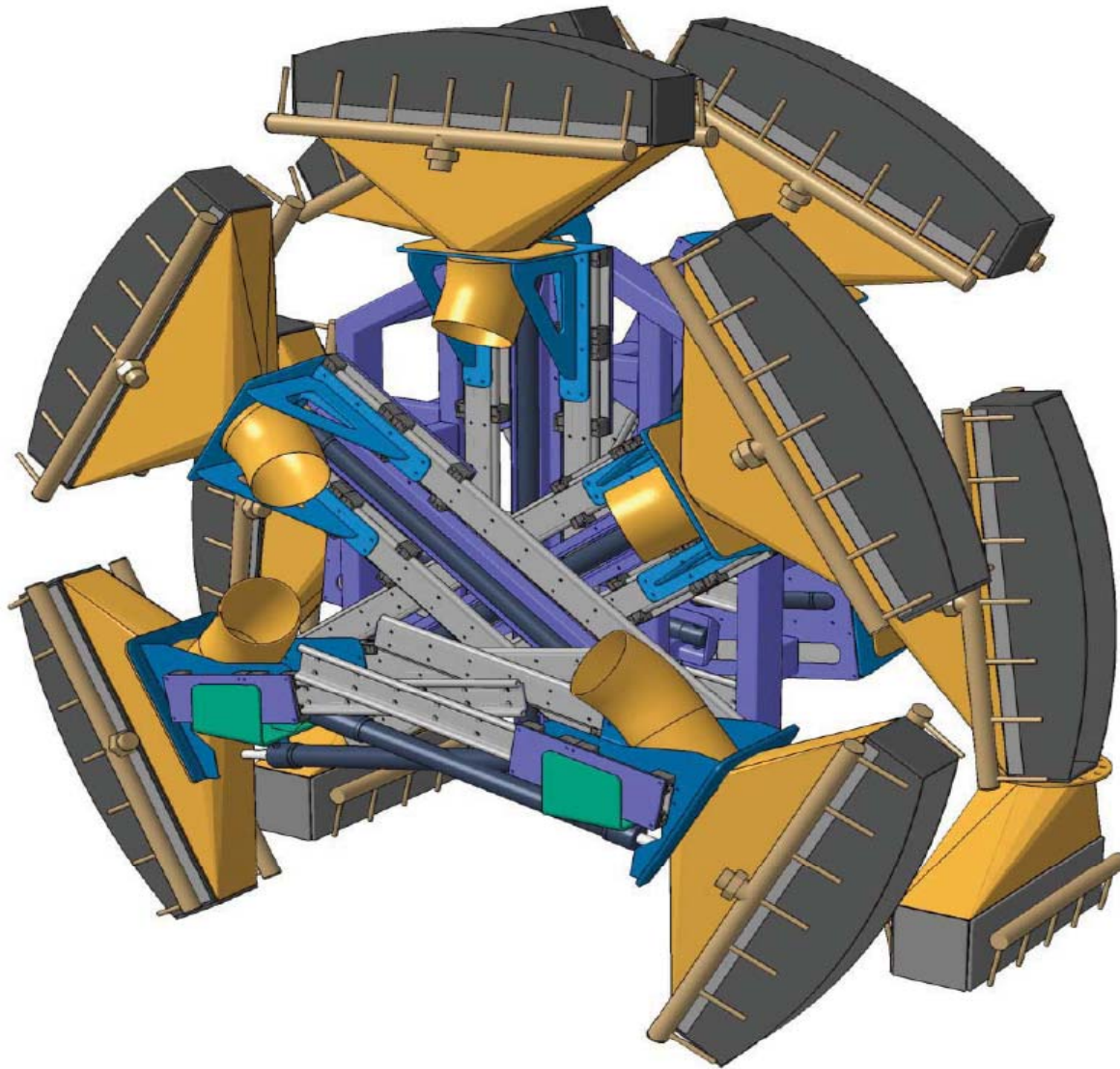

- New train has no “blind spots” – the old train could not clean the tunnel roof and was ineffective in open sections.



# What is different to the old train

- New train can alter its gauge to optimise cleaning in a range of tunnel bores.
- Fully automated process via vehicle mounted Class 1 (“eye-safe”) laser system

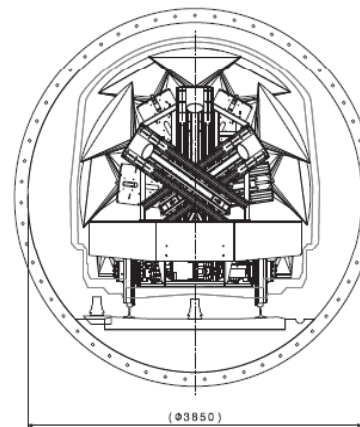
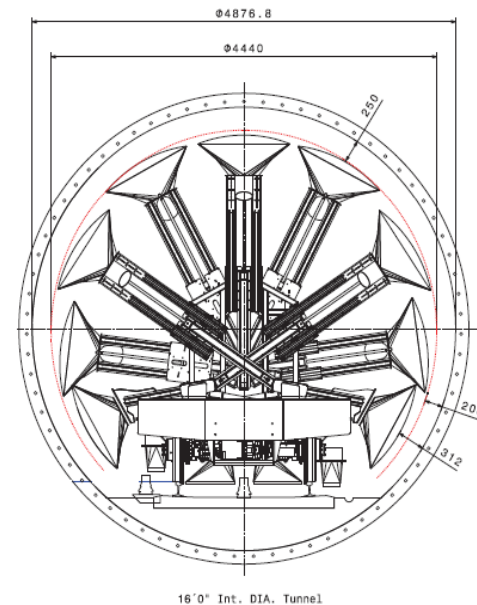

# What is different to the old train

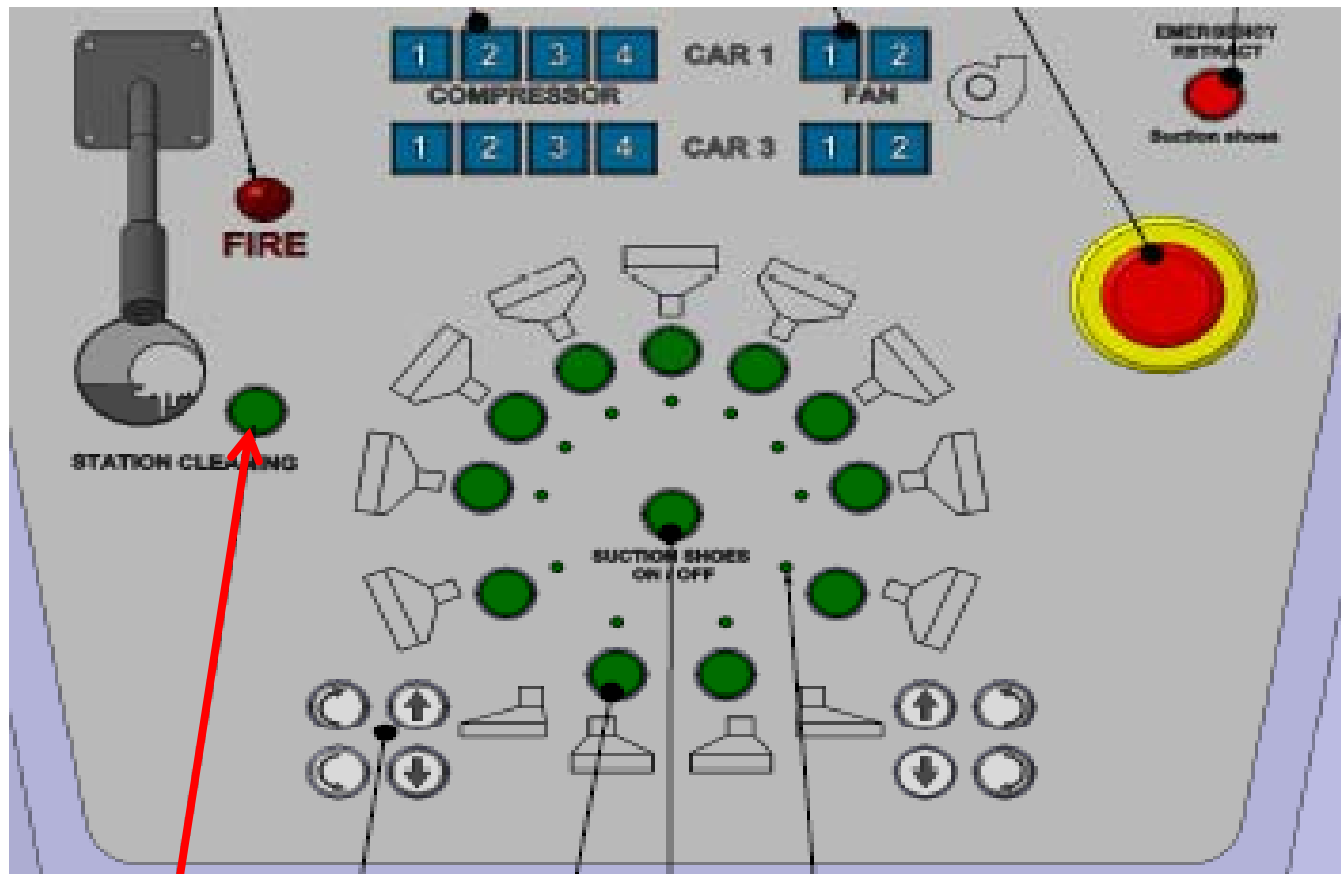

New train has “station cleaning” mode, which isolates the upper nozzles and retracts them to avoid blowing dust onto the platforms. This can also be set to “suction only” if required to avoid a dust plume.



# Lessons to be learnt...

- Old train design was effective at cleaning the tunnels, but had significant room for improvement
- Numerous performance and safety features have been incorporated into the new design
- Operation of the old train was sporadic, it ran on an “as needed” basis due to the slow speed and requirement for a lot of access
- Operation of the new train will be centrally planned and synchronised with stations cleaning team. The train will be far faster due to single pass cleaning, with correspondingly lower access requirements
- New train should lead to a step change in cleanliness in LU’s tunnels



# In closing...

A brief video describing the old train and a rendering of a similar train from the new supplier are available in Livelink at the following address:

- <http://llinkdms.mr.int/livelink/livelink.exe?func=ll&objId=160937790&objAction=browse&viewType=1>

Questions to

(CPD)

